



ARTOME



The Game Changer

Artome M10 combines Nordic design and technology in a way you've never seen before. It is a fully movable piece of smart furniture with a built-in laser projector, an embedded sound system and videoconferencing capabilities. This all-in-one product requires no installation and can be connected to any device with a HDMI-cable or wirelessly.

Sounds almost too good to be true, right?

All-in-One

Artome brings new kind of flexibility to the presentation technology industry. We say no to traditional electrical planning and cabling by creating solutions that are installation free. When all the devices are integrated into the Artome M10, it does not only save time and money in construction, but it also ensures that image and sound always work seamlessly together.

"We renovated the office and decided to invest in design-wise and easy-to-use solutions. With Artome M10 it is easy to execute remote meetings with our clients and it fits to our interior design so nicely too."

Mari Tammivaara
Team assistant at Verona International Oy



Scan for full story!



Easy

Artome M10 enables effortless presenting and videoconferencing. It is easy to move from one place to another and only a light-coloured wall or a screen is needed as a reflection surface. Connecting Artome M10 with different devices is flexible. No additional installations of drivers or software are needed, just add power.

"How much do we use Artome M10? All the time! It is so simple to use with remote or on-location meetings. Just plug a HDMI-wire to the laptop and you are good to go."

Ulla Hemminki-Reijonen
Community Manager of Helsinki Education Hub



Movable

Artome M10 makes the communication visually clear for everyone in the room. The image size can be easily increased up to 150" with the built-in Epson ultra-short throw laser projector. Movable Artome M10 adapts from a videoconference call to a presentation in the lounge area or even to an after work karaoke party, maximizing the utilization rate of the technology.

"Artome M10 solution didn't only fit to the unique atmosphere of our premises, but it also made it possible to get rid of the additional cables and wires"

Robin Lindroos
IT specialist at World Heritage Site Suomenlinna



Scan for full story!





Far more than furniture



Customizable



Frame options



White
Laminate
(default)



Lacquered
Ash veneer

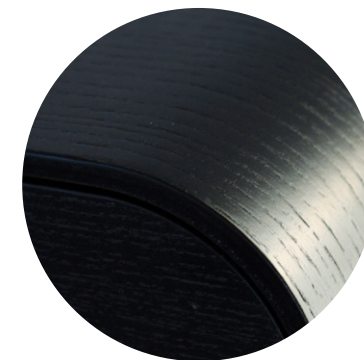

Black stained
Ash veneer

Fabric colors



Sand
(default)

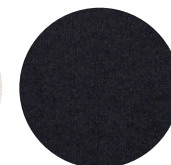

Black

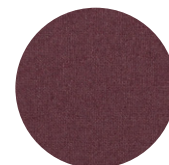

Dark grape

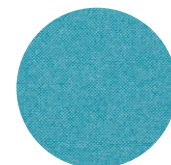

Lagoon

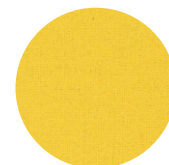

Saffron

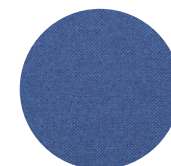

Sea

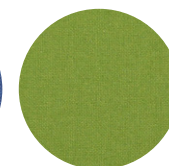

Grass

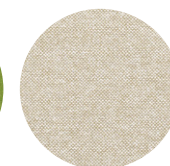

Taupe

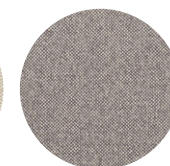

Melange

Built-in technology

Artome offers a flexible experience for remote and live communication by merging the presentation devices into one product. Our own technology enables the camera and microphones to work seamlessly together in all situations.

Artome technology

The secret behind the ease is Artome HybriDock™. This innovation provides a plug-and-play user experience with all laptops and operating systems.

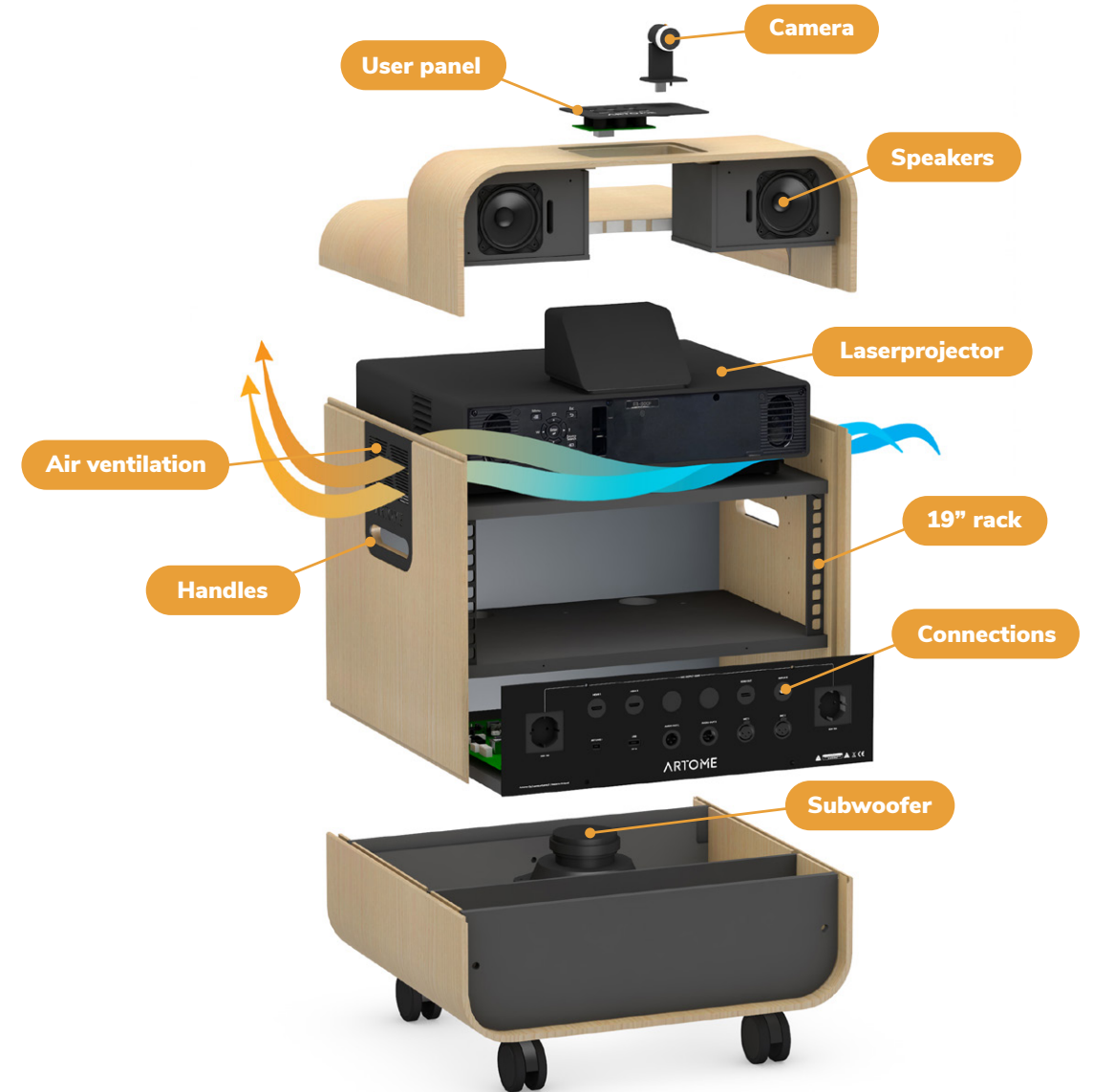

Connections

HDMI 1

Laptop

HDMI 2

Wireless

ARTOME+

Videoconferencing

USB

Conference mic

AUDIO OUT L&R

External speakers

MIC 1&2

Microphone for local presenting & HybriDock

HDMI OUT

Connecting multiple displays or Artome

EPSON® USB

Content playback from USB-memorystick with Epson® (PC-free feature)

Connection for Miracast® (adapter for wireless network projection from mobile device or Windows® computer)

HDBT (located in the back panel)

Video and audio transmission



ARTOME M10

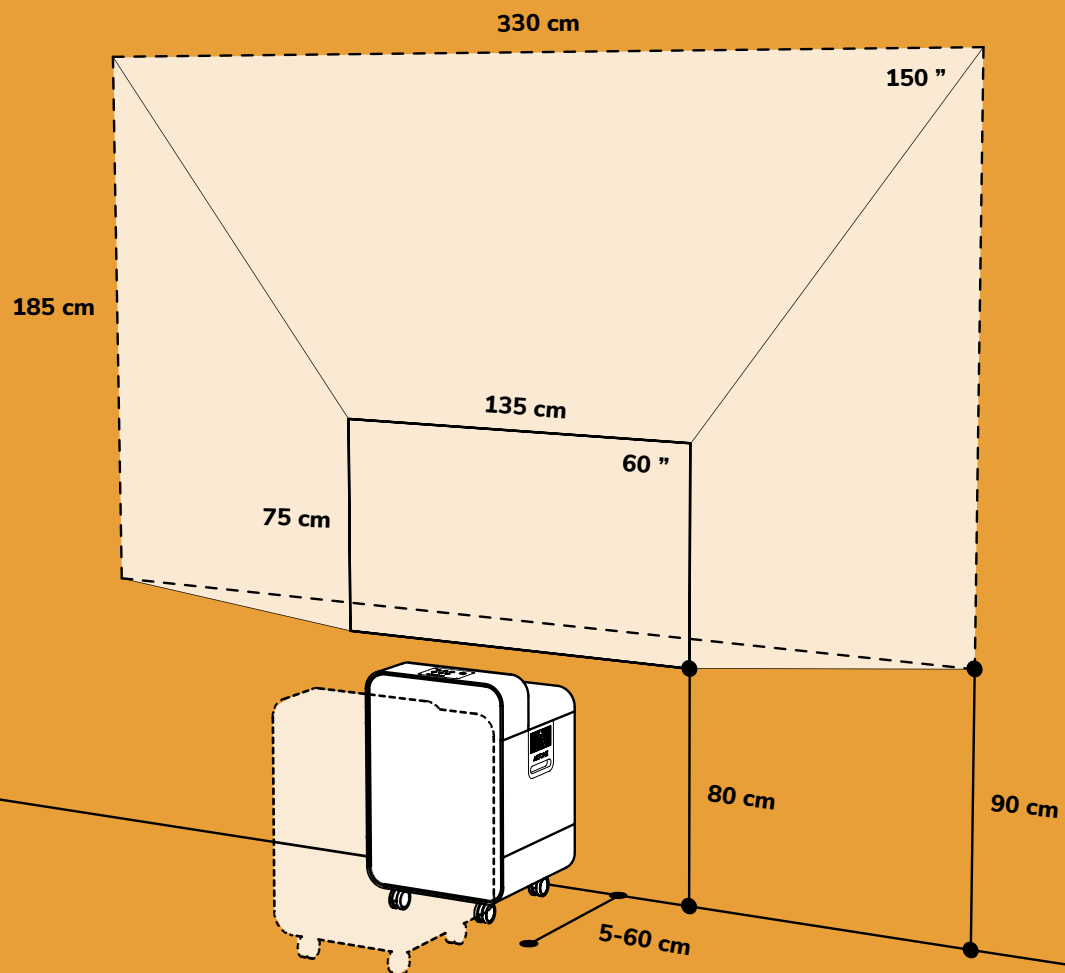

General specs

Name	Artome M10
Product code	43030-002
Materials	Birch plywood, MDF, steel, aluminum
Dimensions	(W x H x D) 52 x 80 x 47,5 cm
Weight	49 kg
19" rack	3 U
Package size	(W x H x D) 80 x 94 x 60 cm
Number of packages	1
Warranty	24 months Projector 5 years or 12000 h

Technical specs

Projector	Epson EB-805F
Resolution	Full HD 1080p, 1920 x 1080, 16:9
Brightness	5000 lm
Sound	Embedded 2.1 -speaker system Max. SPL 108 dB @ 1 m
Image size	60"-150"
Connections	HDMI in x2 HDMI out Mic in x2 Stereo audio out (balanced) HDBaseT
Controls	Power, Source, Vol +/-, Pause, Freeze
Artome HybriDock™	USB 3.0 hub USB audio interface Power delivery for peripherals

ARTOME M10



artome.fi